



Dual N-Channel Enhancement Mode MOSFET

Product Summary		
V _{DS} (V)	I _D (A)	R _{DS(ON)} (mΩ) Max
20V	6A	30 @V _{GS} = 4.0V
		40 @V _{GS} = 2.5V

FEATURES

- ◆ Super high dense cell design for low R_{DS(ON)}.
- ◆ Rugged and reliable.
- ◆ Surface Mount package.

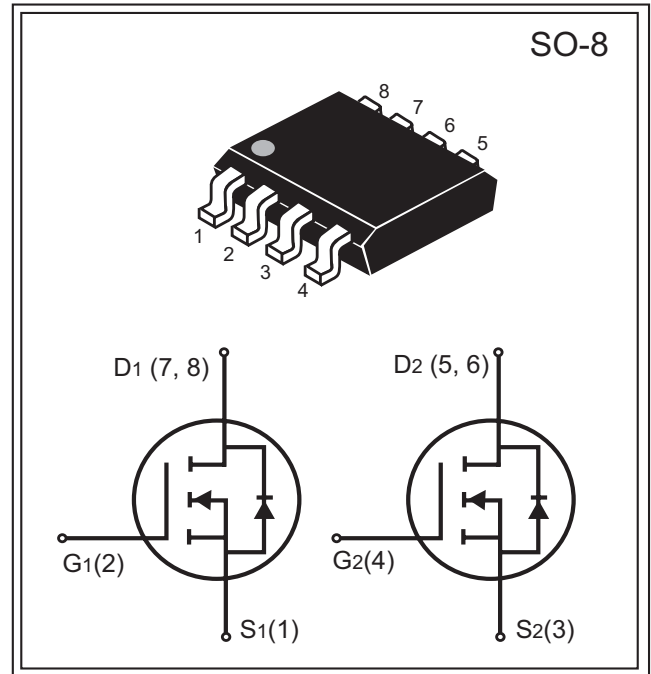

ABSOLUTE MAXIMUM RATINGS (T _A = 25°C unless otherwise noted)			
Parameter	Symbol	Limit	Unit
Drain-Source Voltage	V _{DS}	20	V
Gate-Source Voltage	V _{GS}	±10	V
Drain Current-Continuous @ T _C = 25°C	I _D	6	A
-Pulsed ^b	I _{DM}	35	A
Drain-Source Diode Forward Current ^a	I _S	1.7	A
Maximum Power Dissipation ^a	P _D	2	W
Operating Junction and Storage Temperature Range	T _J , T _{STG}	-55 to 150	°C
THERMAL CHARACTERISTICS			
Thermal Resistance, Junction-to-Ambient ^a	R _{θJA}	62.5	°C/W

South Sea Semiconductor reserves the right to make changes to improve reliability or manufacturability without advance notice.



Electrical Characteristics (TA = 25°C unless otherwise noted)						
Parameter	Symbol	Condition	Min	Typ ^c	Max	Unit
Drain-Source Breakdown Voltage	BV _{DSS}	V _{GS} =0V, I _D =250 μA	20			V
Zero Gate Voltage Drain Current	I _{DSS}	V _{DS} =16V, V _{GS} =0V			1	μA
Gate-Body Leakage	I _{GSS}	V _{GS} =±10V, V _{DS} =0V			±100	nA
Gate Threshold Voltage	V _{GS(th)}	V _{DS} =V _{GS} I _D =250 μA	0.6			V
Drain-Source On-State Resistance	R _{DS(ON)}	V _{GS} =4.0V, I _D =6A		25	30	mΩ
		V _{GS} =2.5V, I _D =6A		35	40	
Forward Transconductance	g _{FS}	V _{DS} =5V, I _D =6A		11.5		S
Input Capacitance	C _{ISS}	V _{DS} =8V		908		pF
Output Capacitance	C _{OSS}	V _{GS} =0V		192		
Reverse Transfer Capacitance	C _{RSS}	f=1.0MHz		151		
Turn-On Delay Time	t _{D(ON)}	V _D =10V, I _D =1A, V _{GEN} =4.5V, R _{GEN} =10Ω, R _L =10Ω		35		ns
Rise Time	t _r			13		
Turn-Off Delay Time	t _{D(OFF)}			45		
Fall Time	t _f			25		
Total Gate Charge	Q _g	V _{DS} =10V, I _D =1A, V _{GS} =4.5V		15		nC
Gate-Source Charge	Q _{gs}			2.5		
Gate-Drain Charge	Q _{gd}			2.5		
Diode Forward Voltage	V _{SD}	V _{GS} =0V, I _D =1.7A		0.7	1.2	V

Notes :

- a. Surface Mounted on FR4 Board, t ≤ 10 sec.
- b. Pulse Test : Pulse Width ≤ 300 μs, Duty Cycle ≤ 2%.
- c. Guaranteed by design, not subject to production testing.

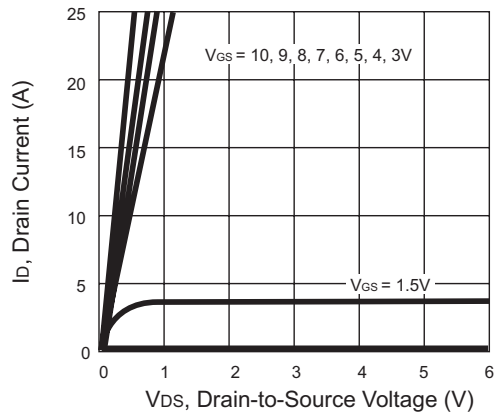

Figure 1. Output Characteristics

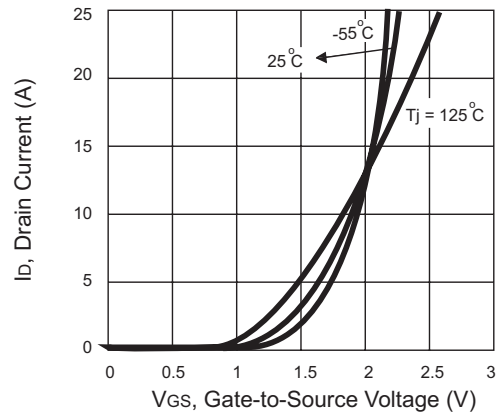

Figure 2. Transfer Characteristics

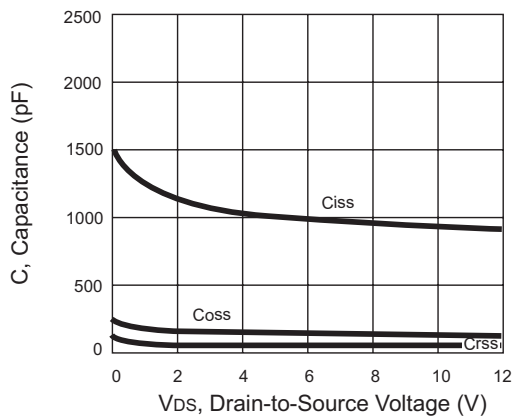

Figure 3. Capacitance

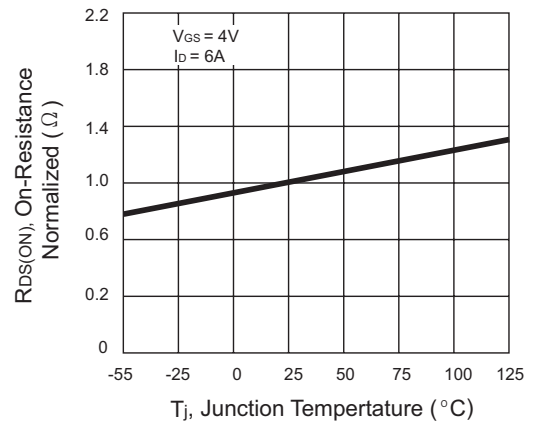

Figure 4. On-Resistance Variation with Temperature

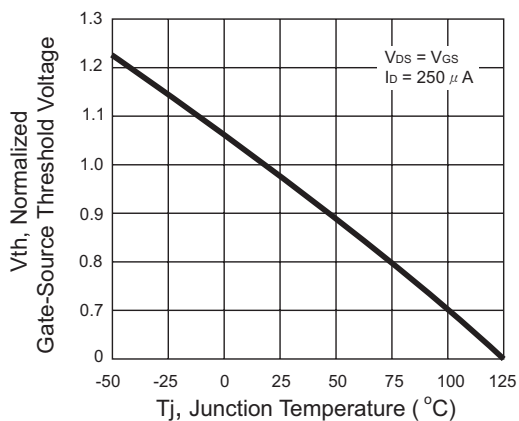

Figure 5. Gate Threshold Variation with Temperature

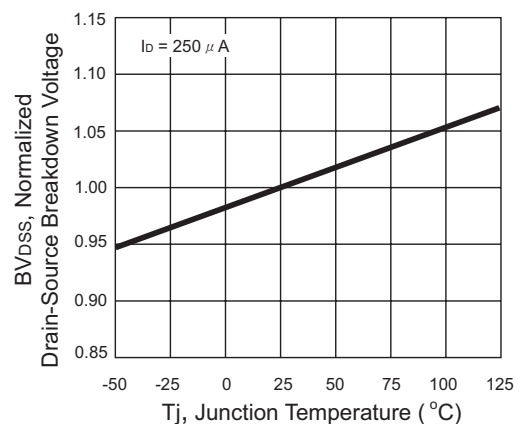

Figure 6. Breakdown Voltage Variation with Temperature

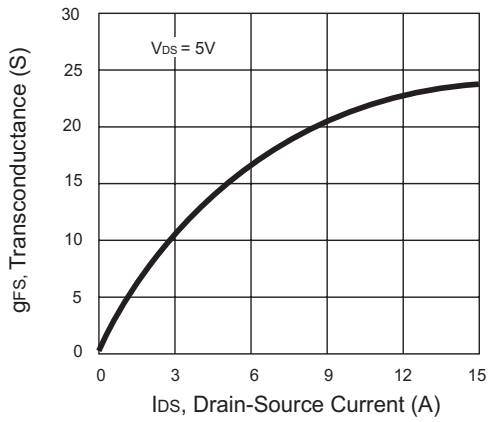

Figure 7. Transconductance Variation with Drain Current

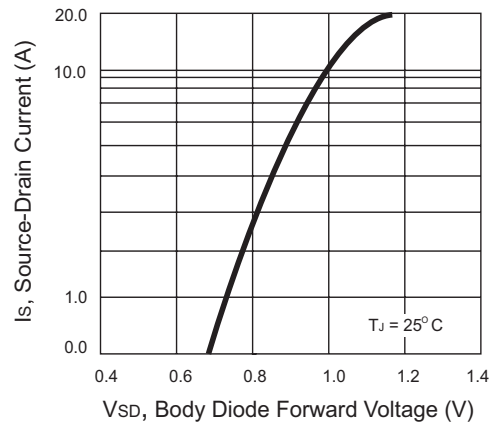

Figure 8. Body Diode Forward Voltage Variation with Source Current

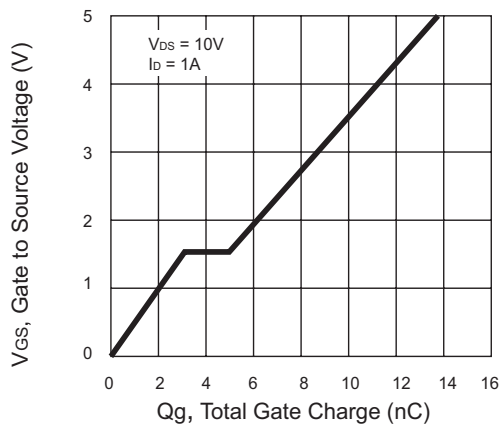

Figure 9. Gate Charge

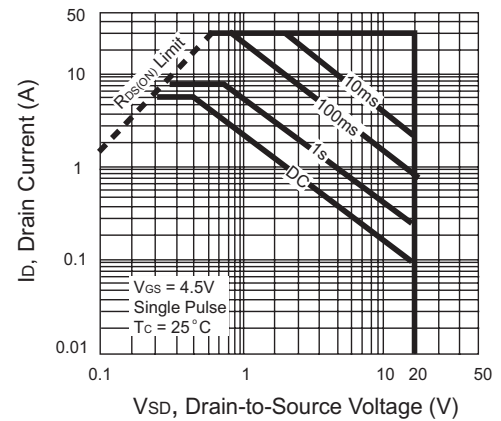

Figure 10. Maximum Safe Operating Area

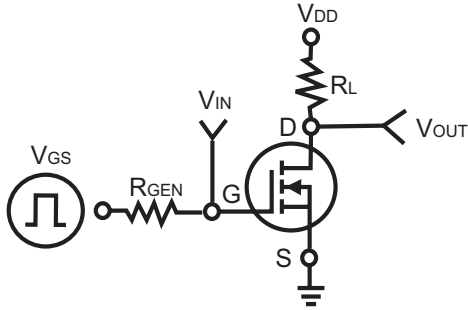

Figure 11. Switching Test Circuit

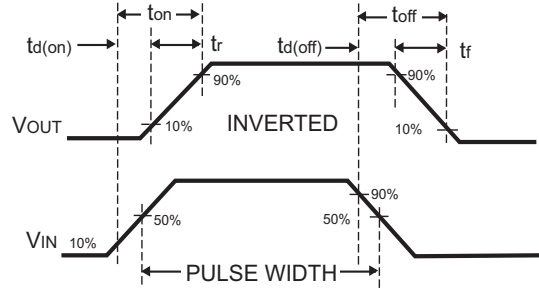

Figure 12. Switching Waveforms

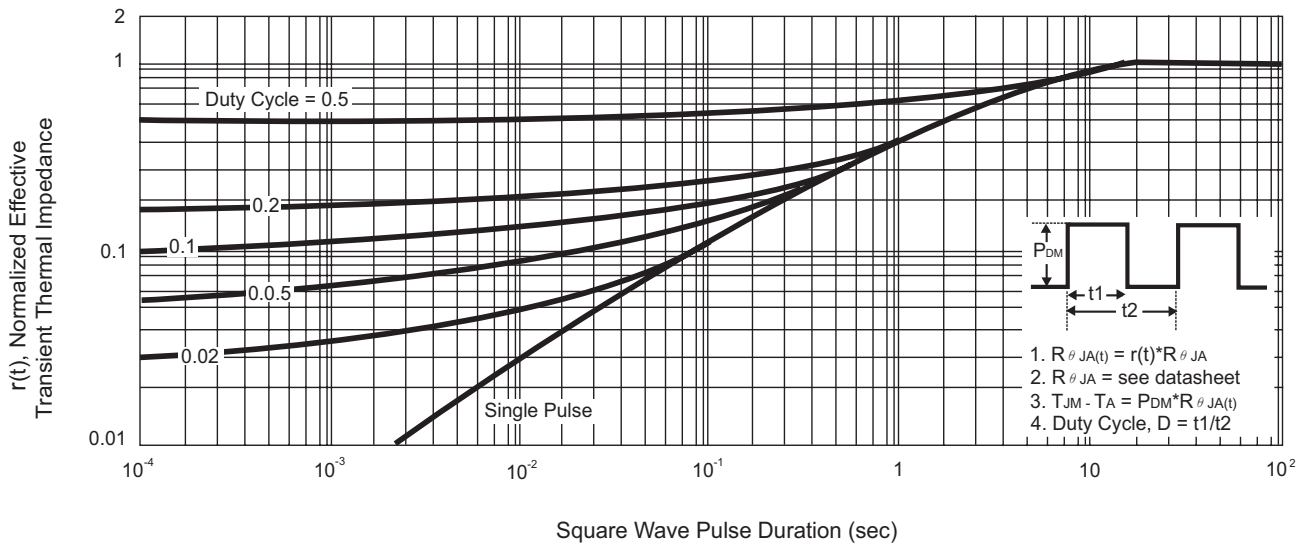
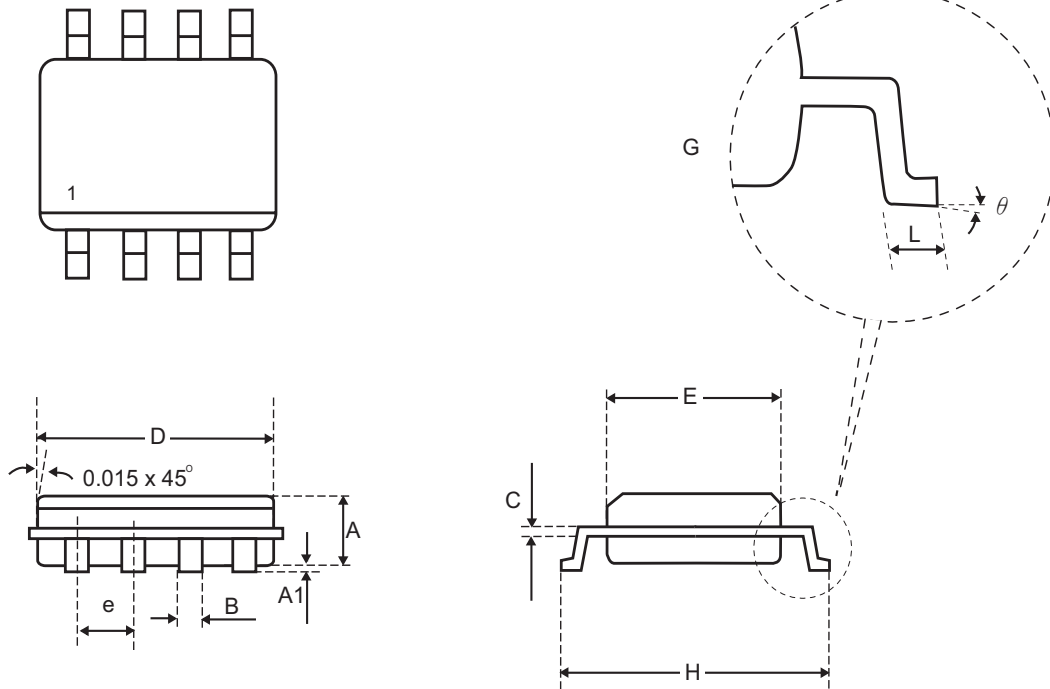

Figure 13. Normalized Thermal Transient Impedance Curve



Package Outline Dimensions

SO-8



SYMBOLS	MILLIMETERS		INCHES	
	Min.	Max.	Min.	Max.
A	1.35	1.75	0.053	0.069
A1	0.10	0.25	0.004	0.010
B	0.41 Typ.		0.016 Typ.	
C	0.20 Typ.		0.008 Typ.	
D	4.80	4.98	0.189	0.196
E	3.81	3.99	0.150	0.157
e	1.25 Typ.		0.05 Typ.	
H	5.79	6.20	0.228	0.244
L	0.41	1.27	0.016	0.050
θ	0°	8°	0°	8°



Carrier Tape & Reel Dimensions

SO-8

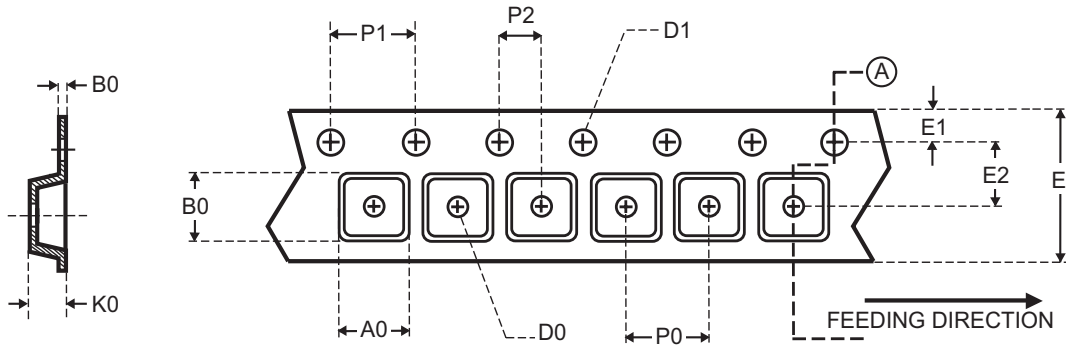

Package	A0	B0	K0	D0	D1	E	E1	E2	P0	P1	P2	T
SOP 8N 150 mil	6.40	5.20	2.10	ψ 1.50 (Min.)	ψ 1.50 +0.10 -0.10	12.00 \pm 0.30	1.75	5.50 \pm 0.05	8.00	4.00	2.00 \pm 0.05	0.30 \pm 0.05

UNIT : mm

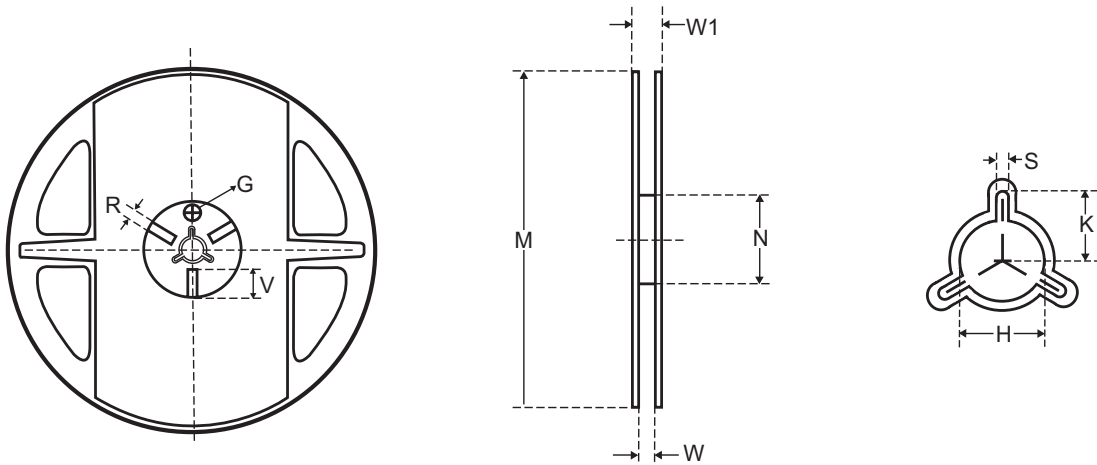

Tape size	Reel Size	M	N	W	W1	H	K	S	G	R	V
12mm	ψ 330	330 \pm 1	62 \pm 1.5	12.4 \pm 0.2	16.8 -0.4	ψ 12.75 \pm 0.15	-	2.0 \pm 0.15	-	-	-

UNIT : mm