

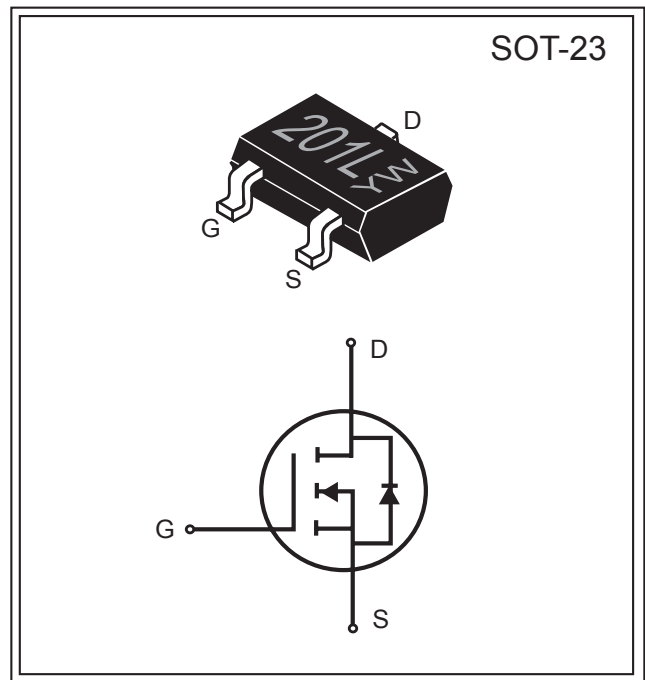

Product Summary		
V _{DS} (V)	I _D (A)	R _{DS(ON)} (Ω) Max
20V	0.5A	1.3 @V _{GS} = 4.5V
		1.6 @V _{GS} = 2.5V



FEATURES

- ◆ Super high density cell design for low R_{DS(ON)}.
- ◆ Rugged and reliable.
- ◆ SOT-23 package.
- ◆ Pb free.

ABSOLUTE MAXIMUM RATINGS (T_A = 25°C unless otherwise noted)

Parameter	Symbol	Limit	Unit
Drain-Source Voltage	V _{DS}	20	V
Gate-Source Voltage	V _{GS}	±12	V
Drain Current-Continuous @ T _c = 25°C	I _D	0.5	A
-Pulsed ^b	I _{DM}	0.8	A
Drain-Source Diode Forward Current ^a	I _S	0.5	A
Maximum Power Dissipation ^a	P _D	0.35	W
Operating Junction and Storage Temperature Range	T _J , T _{STG}	-55 to 150	°C

THERMAL CHARACTERISTICS

Thermal Resistance, Junction-to-Ambient ^a	R _{θJA}	357	°C/W
--	------------------	-----	------

South Sea Semiconductor reserves the right to make changes to improve reliability or manufacturability without advance notice.

South Sea Semiconductor, November 2007 (Rev 1.0)



Electrical Characteristics (T _A = 25°C unless otherwise noted)						
Parameter	Symbol	Condition	Min	Typ ^c	Max	Unit
Drain-Source Breakdown Voltage	BV _{DSS}	V _{GS} =0V, I _D =250 μA	20			V
Zero Gate Voltage Drain Current	I _{DSS}	V _{DS} =20V, V _{GS} =0V			1	μA
Gate-Body Leakage	I _{GSS}	V _{GS} =±10V, V _{DS} =0V			±100	nA
Gate Threshold Voltage	V _{GS(th)}	V _{DS} =V _{GS} I _D =250 μA	0.6	0.8	1.2	V
Drain-Source On-State Resistance	R _{DS(ON)}	V _{GS} =4.5V, I _D =0.3A			1.3	Ω
		V _{GS} =2.5V, I _D =0.1A			1.6	
On-State Drain Current	I _{D(ON)}	V _{DS} = 5V, V _{GS} =4.5V	0.5			A
Forward Transconductance	g _{FS}	V _{DS} = 5V, I _D =0.3A		550		mS
Input Capacitance	C _{ISS}	V _{DS} =12V		35		pF
Output Capacitance	C _{OSS}	V _{GS} =0V		19		
Reverse Transfer Capacitance	C _{RSS}	f=1.0MHz		8		
Turn-On Delay Time	t _{D(ON)}	V _{DD} =10V, I _D =0.3A, V _{GEN} =10V, R _{GEN} =6Ω, R _L =50Ω		4	8	ns
Rise Time	t _r			8	15	
Turn-Off Delay Time	t _{D(OFF)}			9	15	
Fall Time	t _f			6	12	
Total Gate Charge	Q _g	V _{DS} =10V,		950	1500	pC
Gate-Source Charge	Q _{gs}	I _D =0.3A,		220		
Gate-Drain Charge	Q _{gd}	V _{GS} = 4.5V		220		
Diode Forward Voltage	V _{SD}	V _{GS} =0V, I _D =0.3A		0.85	1.2	V

Notes :

- a. Surface Mounted on FR4 Board, t ≤ 10 sec.
- b. Pulse Test : Pulse Width ≤ 300 μs, Duty Cycle ≤ 2%.
- c. Guaranteed by design, not subject to production testing.

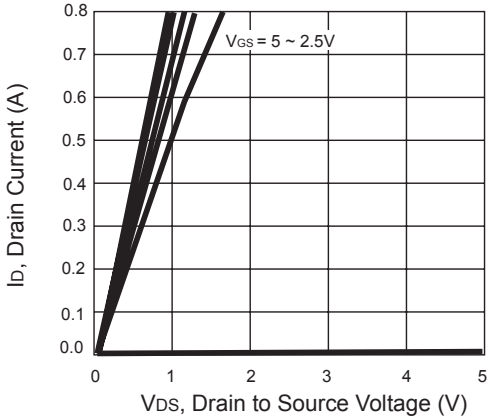

Figure 1. Output Characteristics

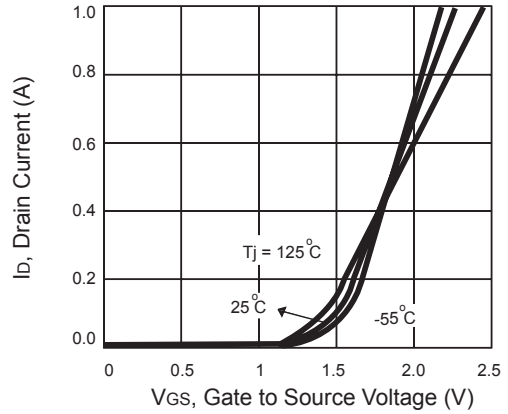

Figure 2. Transfer Characteristics

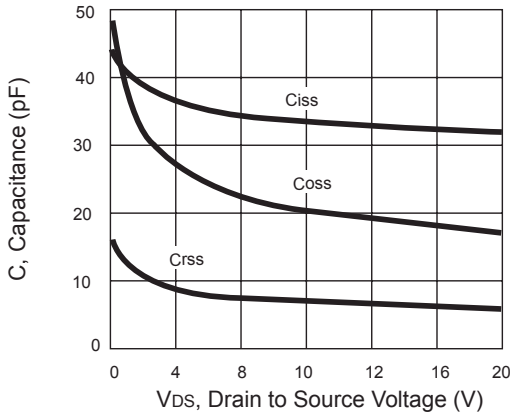

Figure 3. Capacitance

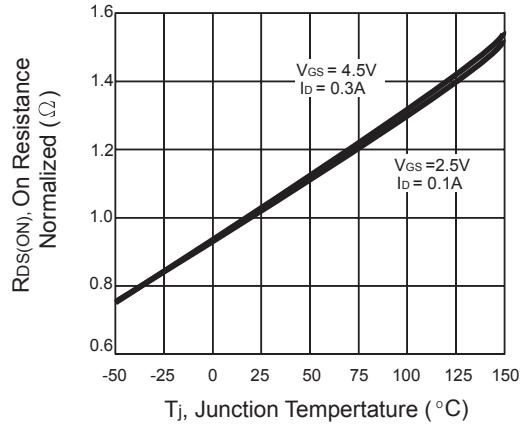

Figure 4. On Resistance Variation with Junction Temperature

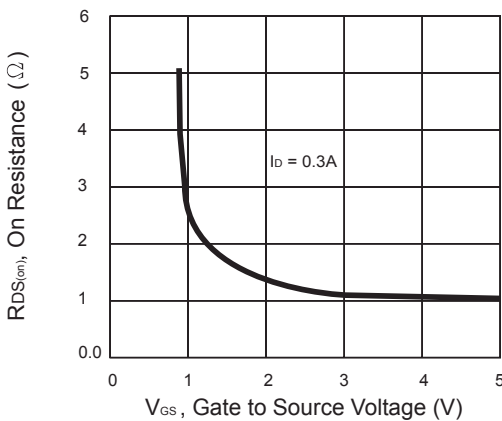

Figure 5. On Resistance Variation with Gate to Source Voltage

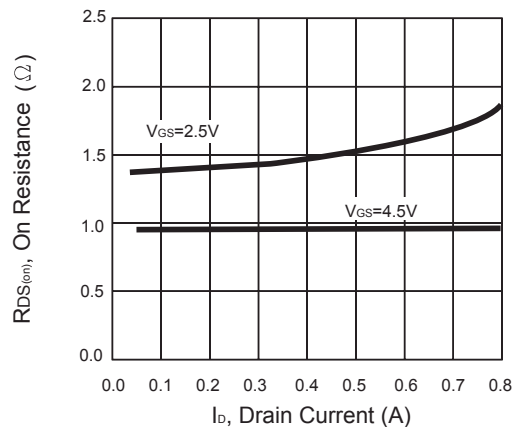

Figure 6. On Resistance Variation with Drain Current

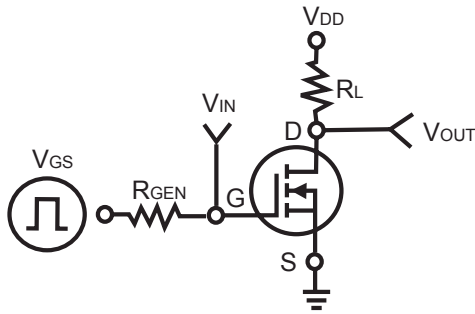

Figure 11. Switching Test Circuit

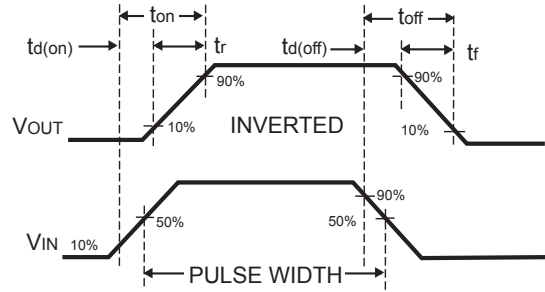

Figure 12. Switching Waveforms

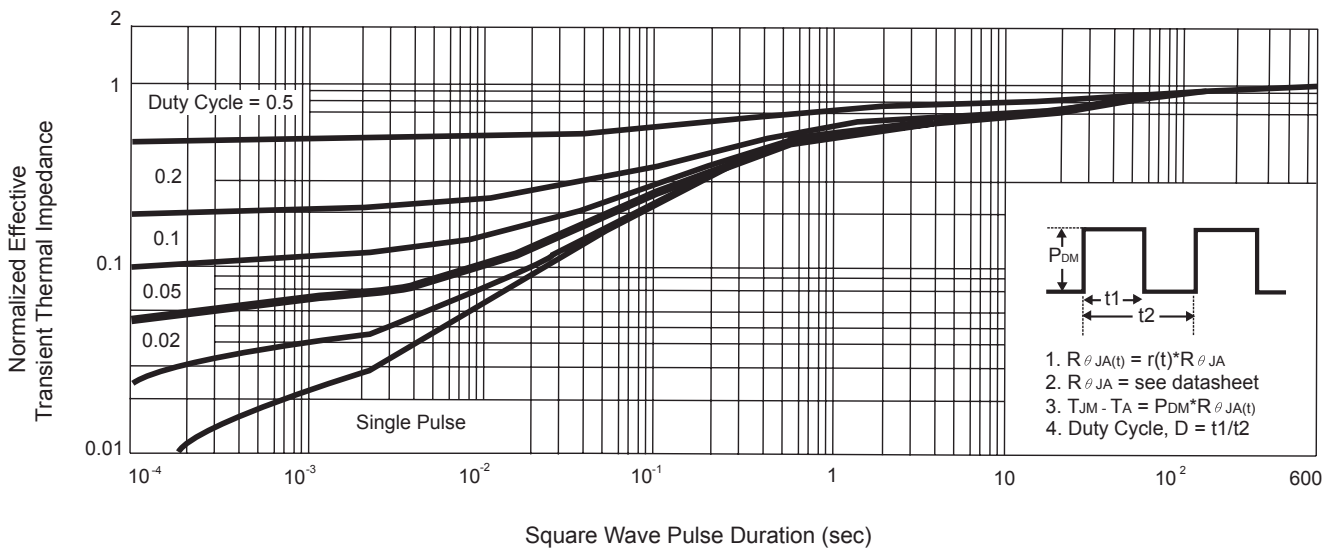

Figure 13. Normalized Thermal Transient Impedance Curve, Junction to Ambient