

Product Summary		
V <sub>DS</sub> (V)	I <sub>D</sub> (A)	R <sub>DS(ON)</sub> (Ω) Max
60V	0.25A	3.0 @V <sub>GS</sub> = 10V
		4.0 @V <sub>GS</sub> = 5V

### FEATURES

- ◆ Super high density cell design for low R<sub>DS(ON)</sub>.
- ◆ Gate-source ESD protection diodes.
- ◆ Rugged and reliable.
- ◆ SOT-23 package.
- ◆ Pb free.

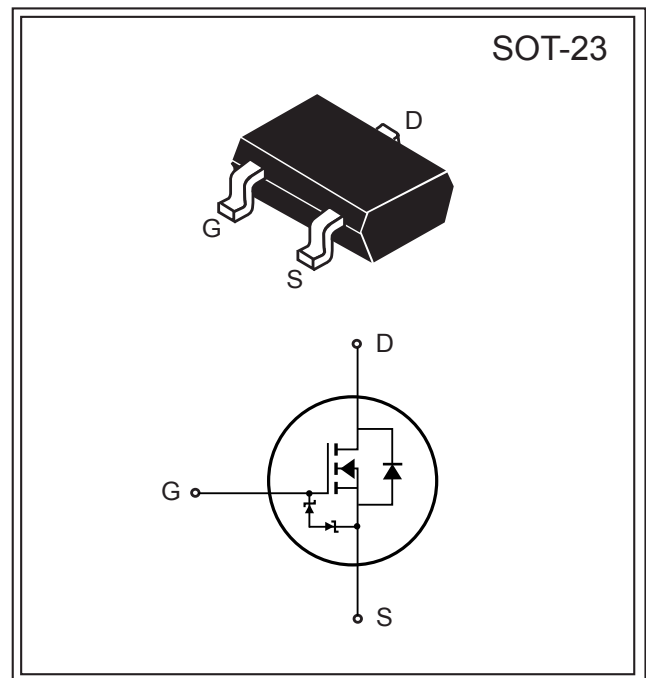

ABSOLUTE MAXIMUM RATINGS (T <sub>A</sub> = 25°C unless otherwise noted)				
Parameter		Symbol	Limit	Unit
Drain-Source Voltage		V <sub>DS</sub>	60	V
Gate-Source Voltage		V <sub>GS</sub>	±20	V
Drain Current-Continuous @ T <sub>J</sub> = 125°C <sup>a</sup>	T <sub>A</sub> = 25°C	I <sub>D</sub>	250	mA
	T <sub>A</sub> = 100°C		190	
-Pulsed <sup>b</sup>		I <sub>DM</sub>	1	A
Drain-Source Diode Forward Current <sup>a</sup>		I <sub>S</sub>	250	mA
Maximum Power Dissipation <sup>a</sup>	T <sub>A</sub> = 25°C	P <sub>D</sub>	200	mW
	T <sub>A</sub> = 100°C		140	
Operating Junction and Storage Temperature Range		T <sub>J</sub> , T <sub>STG</sub>	-55 to 150	°C
THERMAL CHARACTERISTICS				
Thermal Resistance, Junction-to-Ambient <sup>a</sup>		R <sub>θJA</sub>	625	°C/W

South Sea Semiconductor reserves the right to make changes to improve reliability or manufacturability without advance notice.

South Sea Semiconductor, July 2008(Rev 1.1)

N-Channel Electrical Characteristics (TA = 25°C unless otherwise noted)						
Parameter	Symbol	Condition	Min	Typ <sup>c</sup>	Max	Unit
Drain-Source Breakdown Voltage	BV <sub>DSS</sub>	V <sub>GS</sub> =0V, I <sub>D</sub> =10 μA	60			V
Zero Gate Voltage Drain Current	I <sub>DSS</sub>	V <sub>DS</sub> =60V, V <sub>GS</sub> =0V			1	μA
Gate-Body Leakage	I <sub>GSS</sub>	V <sub>GS</sub> =±18V, V <sub>DS</sub> =0V			±10	μA
Gate Threshold Voltage	V <sub>GS(th)</sub>	V <sub>DS</sub> =V <sub>GS</sub> I <sub>D</sub> =250 μA	1	2	2.5	V
Drain-Source On-State Resistance	R <sub>DS(on)</sub>	V <sub>GS</sub> =10V, I <sub>D</sub> =250mA			3	Ω
		V <sub>GS</sub> = 5V, I <sub>D</sub> =50mA			4	
On-State Drain Current	I <sub>D(on)</sub>	V <sub>DS</sub> =7V, V <sub>GS</sub> =10V	495			mA
Forward Transconductance	g <sub>FS</sub>	V <sub>DS</sub> =7V, I <sub>D</sub> =200mA	78			mS
Input Capacitance	C <sub>ISS</sub>	V <sub>DS</sub> =25V		20	50	pF
Output Capacitance	C <sub>OSS</sub>	V <sub>GS</sub> =0V		11	25	
Reverse Transfer Capacitance	C <sub>RSS</sub>	f=1.0MHz		2.5	5	
Turn-On Delay Time	t <sub>D(on)</sub>	V <sub>DD</sub> =30V, I <sub>D</sub> =100mA, V <sub>GS</sub> =10V, R <sub>GEN</sub> =10Ω		7.8	20	ns
Rise Time	t <sub>r</sub>			5.5		
Turn-Off Delay Time	t <sub>D(off)</sub>			7.8	20	
Fall Time	t <sub>f</sub>			2.8		
Diode-Forward Voltage	V <sub>SD</sub>	V <sub>GS</sub> =0V, I <sub>D</sub> =250mA		0.75	1.5	V

Notes :

- Surface Mounted on FR4 Board, t ≤ 10 sec.
- Pulse Test : Pulse Width ≤ 300 μs, Duty Cycle ≤ 2%.
- Guaranteed by design, not subject to production testing.

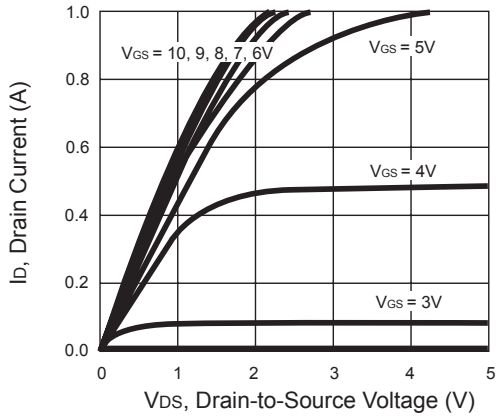

Figure 1. Output Characteristics

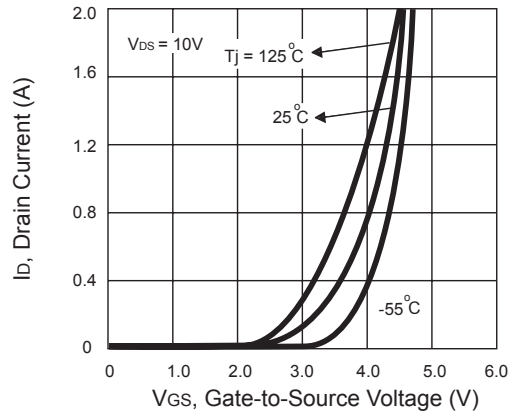

Figure 2. Transfer Characteristics

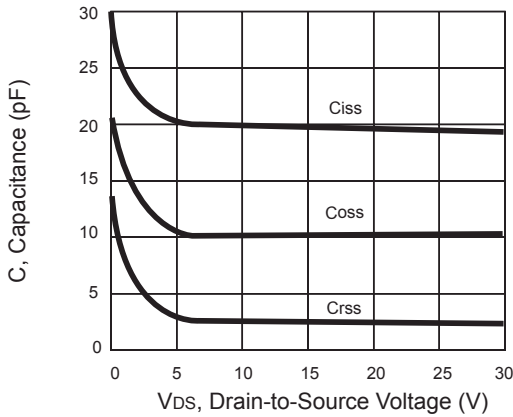

Figure 3. Capacitance

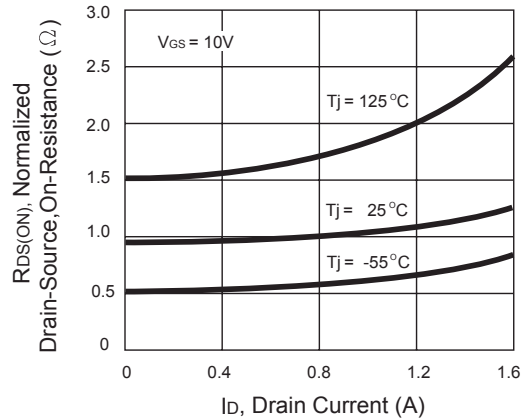

Figure 4. On-Resistance Variation with Temperature

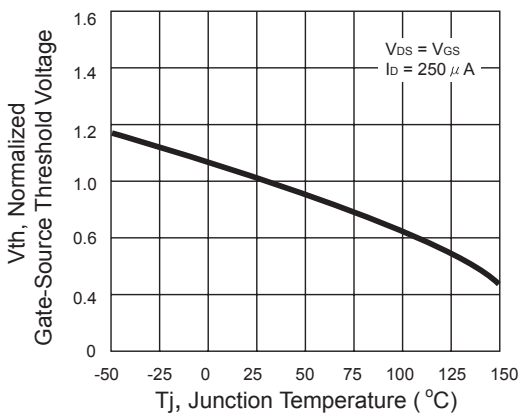

Figure 5. Gate Threshold Variation with Temperature

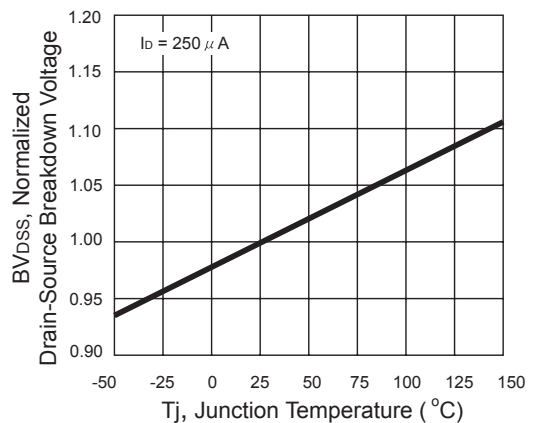

Figure 6. Breakdown Voltage Variation with Temperature

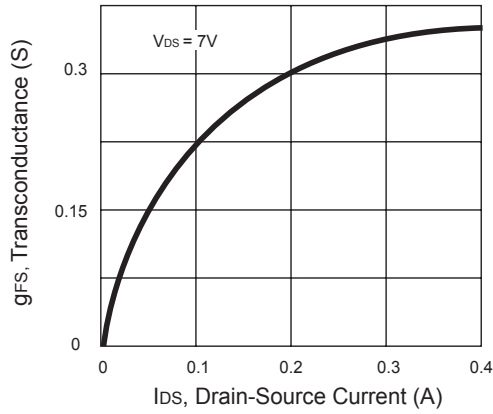

Figure 7. Transconductance Variation with Drain Current

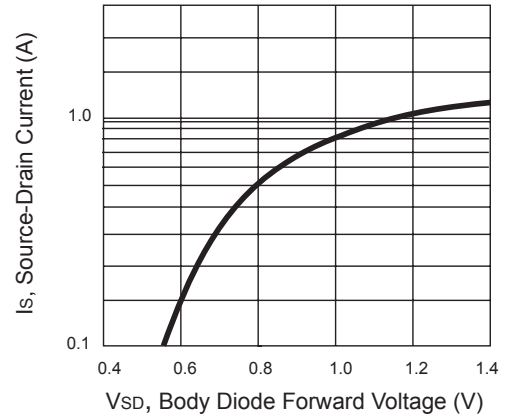

Figure 8. Body Diode Forward Voltage Variation with Source Current

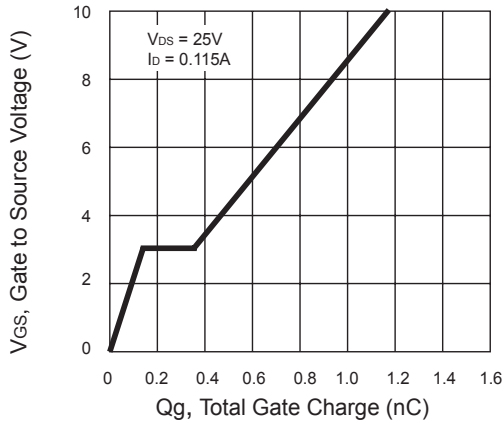

Figure 9. Gate Charge

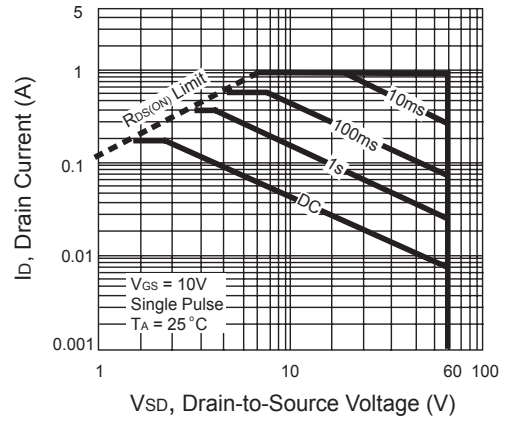

Figure 10. Maximum Safe Operating Area

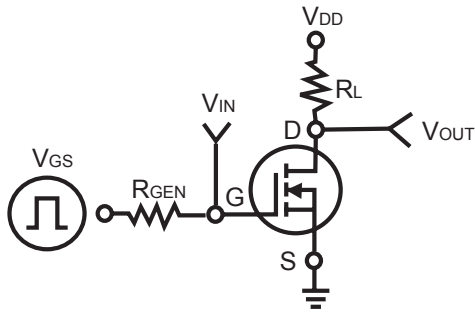

Figure 11. Switching Test Circuit

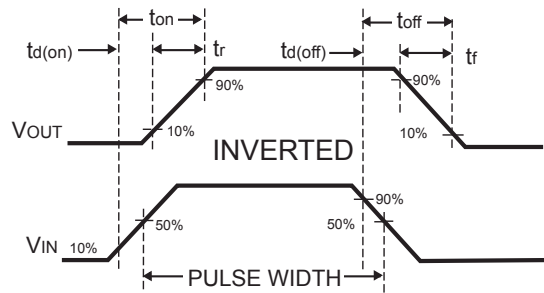

Figure 12. Switching Waveforms

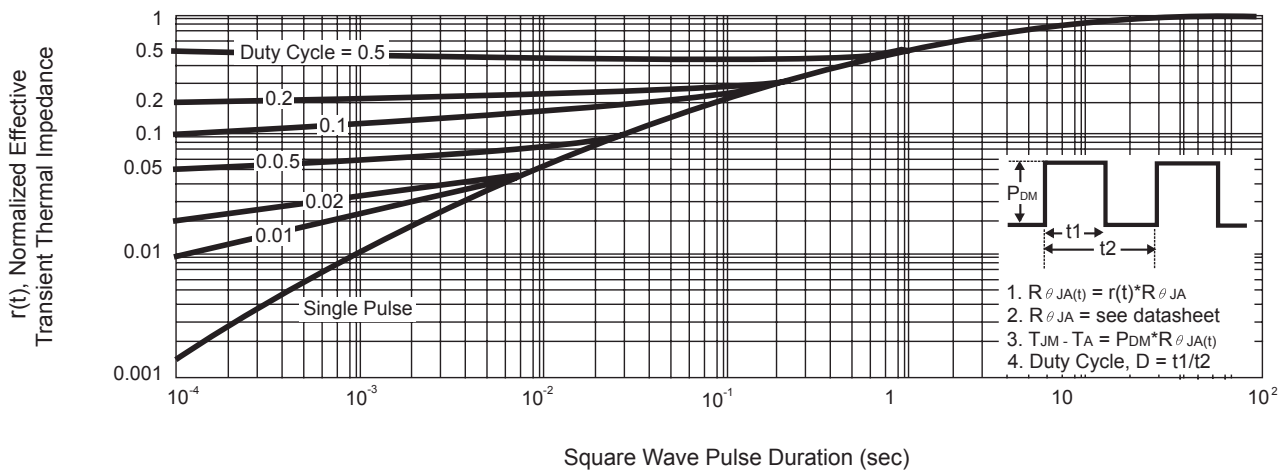

Figure 13. Normalized Thermal Transient Impedance Curve