



Product Summary		
V_{DS} (V)	I_D (A)	$R_{DS(ON)}$ (Ω) Max
60V	0.25A	3 @ $V_{GS} = 10V$
		4 @ $V_{GS} = 5V$

FEATURES

- ◆ Super high dense cell design for low $R_{DS(ON)}$.
- ◆ Rugged and reliable.
- ◆ SOT-363 package.

Marking Code : 2B

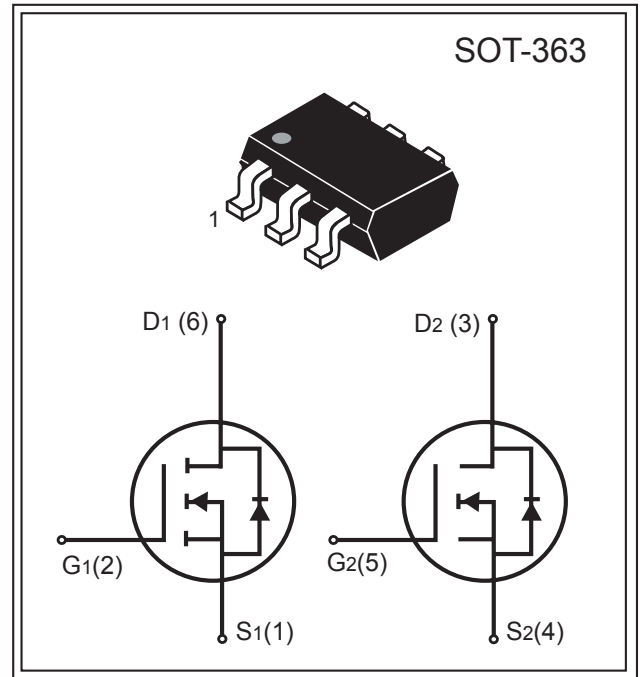

ABSOLUTE MAXIMUM RATINGS ($T_A = 25^\circ C$ unless otherwise noted)			
Parameter	Symbol	Limit	Unit
Drain-Source Voltage	V_{DS}	60	V
Gate-Source Voltage	V_{GS}	± 20	V
Drain Current-Continuous @ $T_J = 125^\circ C$	I_D	250	mA
-Pulsed ^b	I_{DM}	1	A
Drain-Source Diode Forward Current ^a	I_S	250	mA
Maximum Power Dissipation ^a	P_D	200	mW
Operating Junction and Storage Temperature Range	T_J, T_{STG}	-55 to 150	$^\circ C$
THERMAL CHARACTERISTICS			
Thermal Resistance, Junction-to-Ambient ^a	$R_{\theta JA}$	625	$^\circ C/W$

South Sea Semiconductor reserves the right to make changes to improve reliability or manufacturability without advance notice.

N-Channel Electrical Characteristics ($T_A = 25^\circ\text{C}$ unless otherwise noted)

Parameter	Symbol	Condition	Min	Typ ^c	Max	Unit
Drain-Source Breakdown Voltage	BV_{DSS}	$V_{GS}=0V, I_D=10\ \mu A$	60			V
Zero Gate Voltage Drain Current	I_{DSS}	$V_{DS}=60V, V_{GS}=0V$			1	μA
Gate-Body Leakage	I_{GSS}	$V_{GS}=\pm 20V, V_{DS}=0V$			± 100	nA
Gate Threshold Voltage	$V_{GS(th)}$	$V_{DS}=V_{GS}, I_D=250\ \mu A$	1	2	2.5	V
Drain-Source On-State Resistance	$R_{DS(on)}$	$V_{GS}=10V, I_D=250mA$		2.0	3.0	Ω
		$V_{GS}=5V, I_D=50mA$		3.0	4.0	
On-State Drain Current	$I_{D(on)}$	$V_{DS}=7V, V_{GS}=10V$	495			mA
Forward Transconductance	g_{FS}	$V_{DS}=7V, I_D=200mA$	78			mS
Input Capacitance	C_{ISS}	$V_{DS}=25V$		20	50	pF
Output Capacitance	C_{OSS}	$V_{GS}=0V$		11	25	
Reverse Transfer Capacitance	C_{RSS}	$f=1.0MHz$		2.5	5	
Turn-On Delay Time	$t_{D(on)}$	$V_{DD}=30V,$ $I_D=100mA,$ $V_{GS}=10V,$ $R_{GEN}=10\ \Omega$		7.8	20	ns
Rise Time	t_r			5.5		
Turn-Off Delay Time	$t_{D(off)}$			7.8	20	
Fall Time	t_f			2.8		
Diode-Forward Voltage	V_{SD}	$V_{GS}=0V, I_D=250mA$		0.75	1.5	V

Notes :

- Surface Mounted on FR4 Board, $t \leq 10$ sec.
- Pulse Test : Pulse Width $\leq 300\ \mu s$, Duty Cycle $\leq 2\%$.
- Guaranteed by design, not subject to production testing.

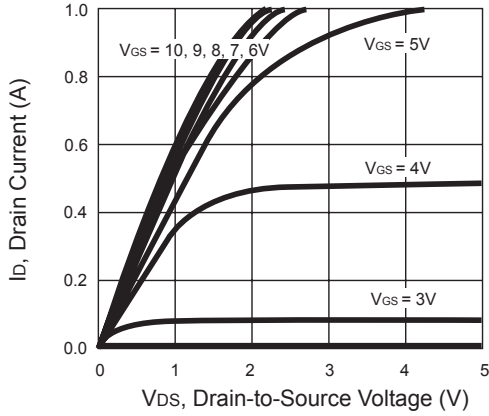

Figure 1. Output Characteristics

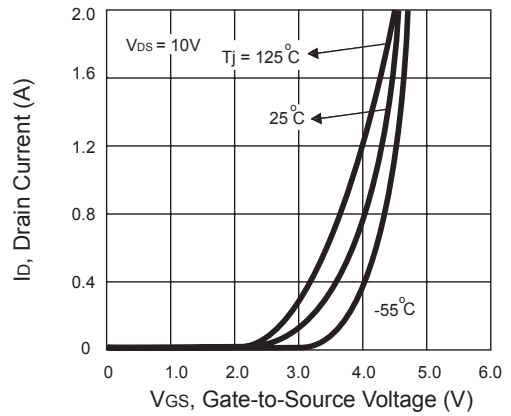

Figure 2. Transfer Characteristics

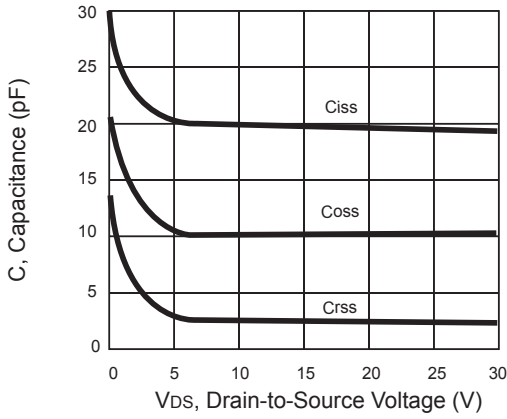

Figure 3. Capacitance

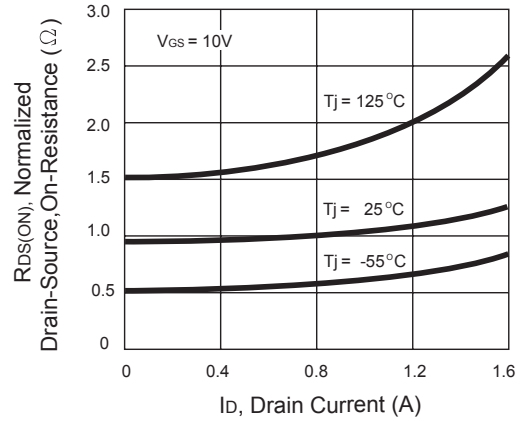

Figure 4. On-Resistance Variation with Temperature

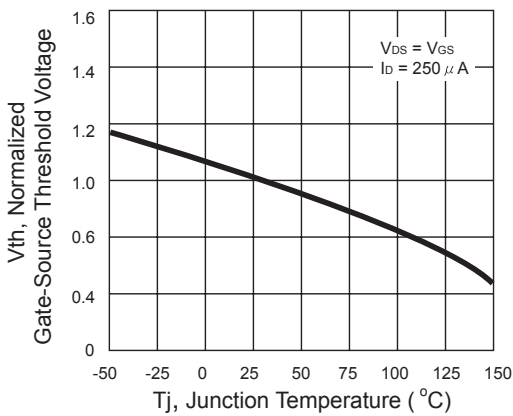

Figure 5. Gate Threshold Variation with Temperature

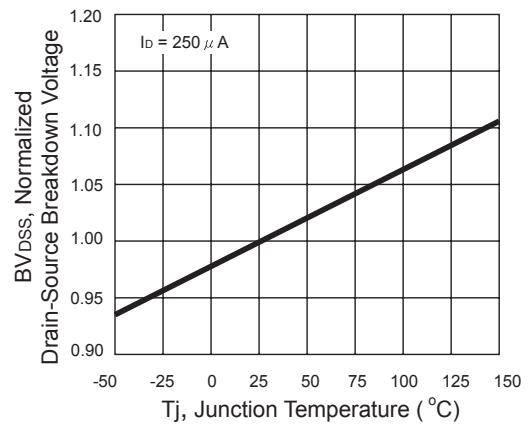

Figure 6. Breakdown Voltage Variation with Temperature

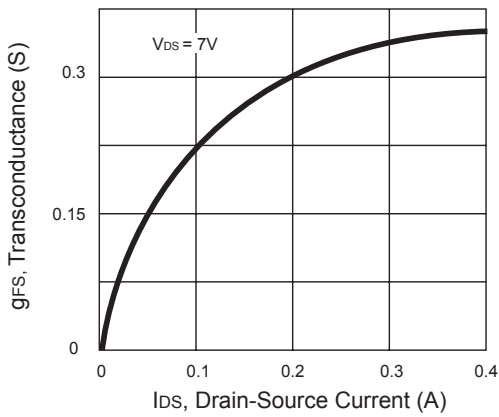

Figure 7. Transconductance Variation with Drain Current

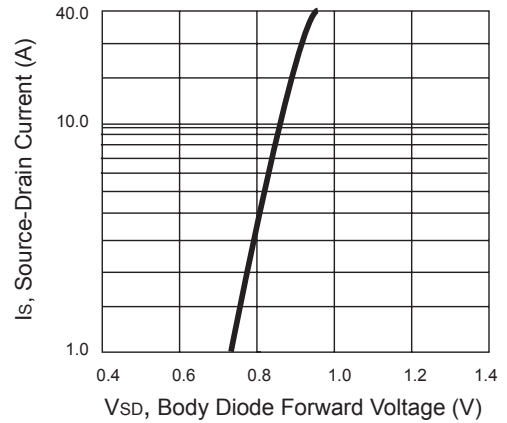

Figure 8. Body Diode Forward Voltage Variation with Source Current

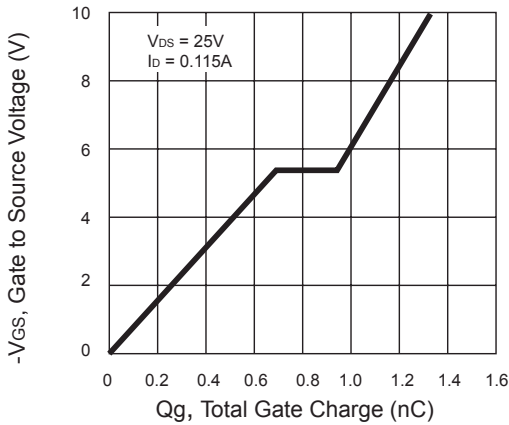

Figure 9. Gate Charge

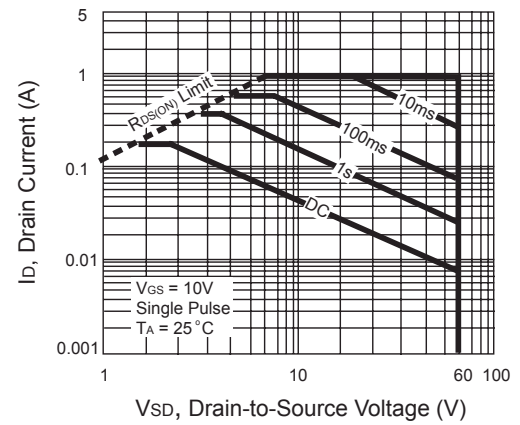

Figure 10. Maximum Safe Operating Area

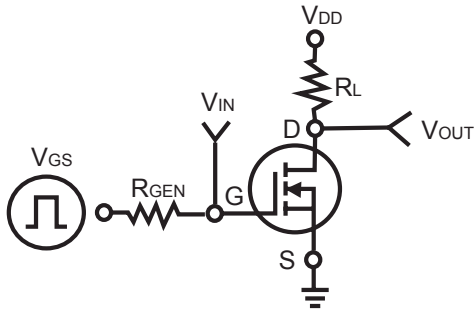

Figure 11. Switching Test Circuit

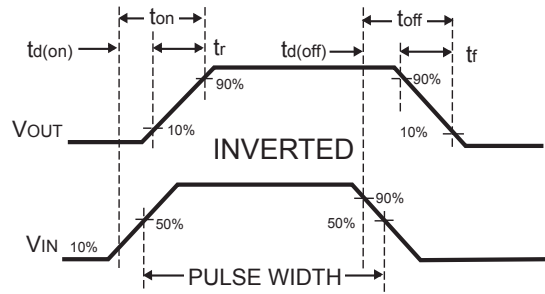

Figure 12. Switching Waveforms

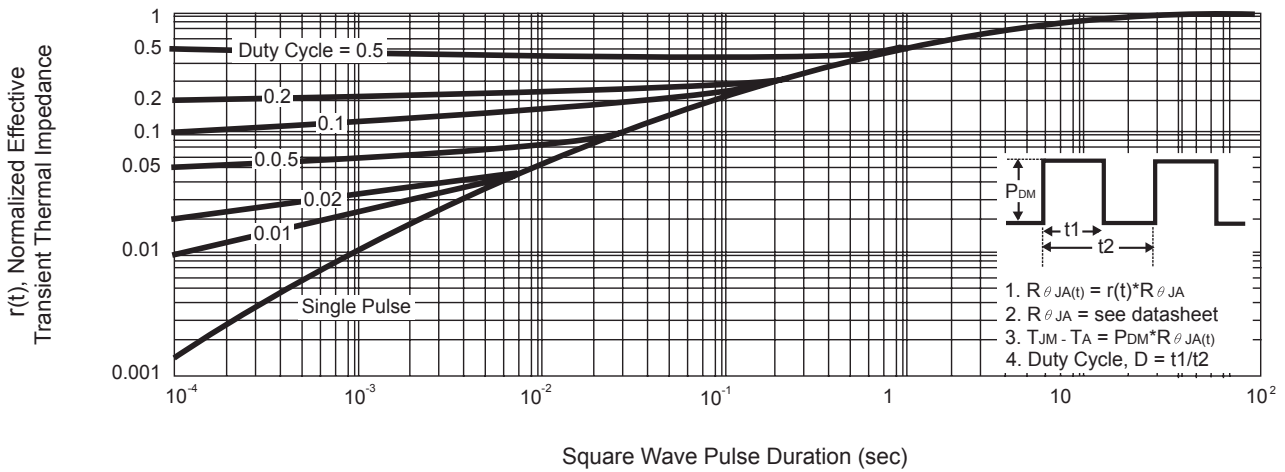
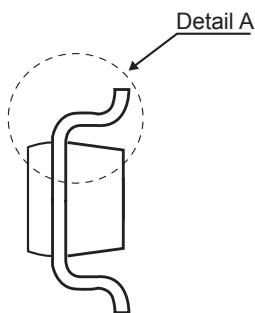
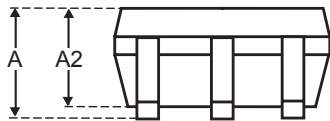
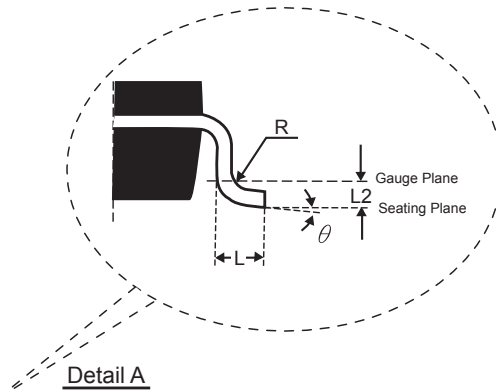
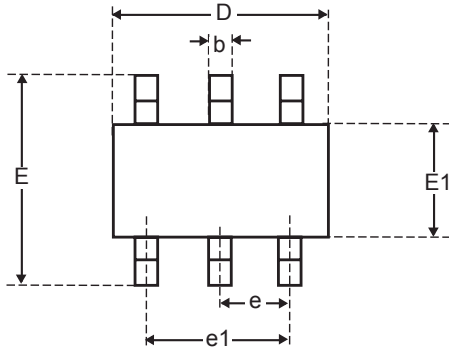

Figure 13. Normalized Thermal Transient Impedance Curve



Package Outline Dimensions

SOT-363



SYMBOLS	MILLIMETERS		
	Min.	Nom.	Max.
A	0.90	–	1.10
A2	0.80	0.90	1.00
b	0.15	0.20	0.30
D	1.80	2.00	2.20
E	2.15	2.30	2.45
E1	1.15	1.25	1.35
e	–	0.65	–
e1	1.20	1.30	1.40
L	0.30	–	0.45
L2	0.10	0.15	0.25
R	0.10	–	–
θ	0°		10°