

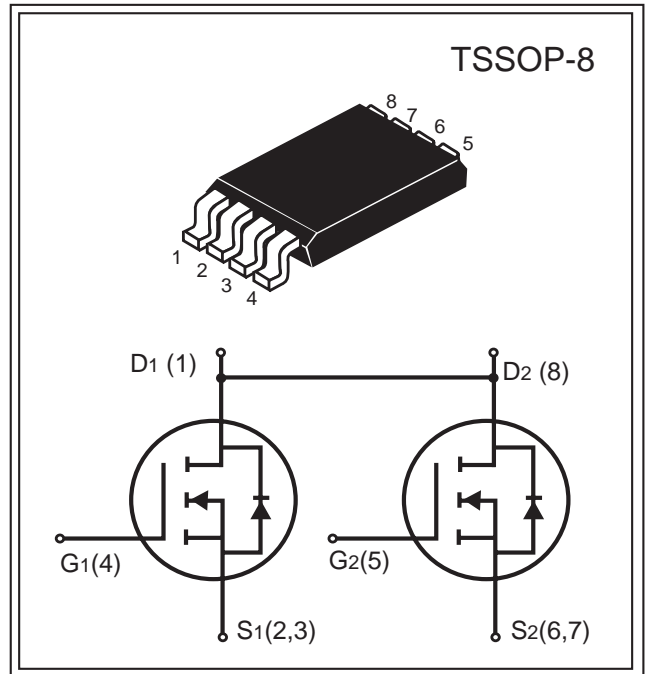

Product Summary		
V _{DS} (V)	I _D (A)	R _{DS(ON)} (mΩ) Typ
20V	7A	18 @V _{GS} = 4.5V
		24 @V _{GS} = 2.5V

FEATURES

- Super high dense cell design for low R_{DS(ON)}.
- Rugged and reliable.
- Surface Mount package.



ABSOLUTE MAXIMUM RATINGS (T _A = 25 °C unless otherwise noted)			
Parameter	Symbol	Limit	Unit
Drain-Source Voltage	V _{DS}	20	V
Gate-Source Voltage	V _{GS}	±12	V
Drain Current-Continuous @ T _c = 25°C	I _D	7	A
-Pulsed ^b	I _{DM}	40	A
Drain-Source Diode Forward Current ^a	I _S	2	A
Maximum Power Dissipation ^a	P _D	1.5	W
Operating Junction and Storage Temperature Range	T _J , T _{STG}	-55 to 150	°C
THERMAL CHARACTERISTICS			
Thermal Resistance, Junction-to-Ambient ^a	R _{JA}	85	°C/W

South Sea Semiconductor reserves the right to make changes to improve reliability or manufacturability without advance notice.



Electrical Characteristics (T _A = 25°C unless otherwise noted)						
Parameter	Symbol	Condition	Min	Typ ^c	Max	Unit
Drain-Source Breakdown Voltage	BV _{DSS}	V _{GS} =0V, I _D =250 μ A	20			V
Zero Gate Voltage Drain Current	I _{DSS}	V _{DS} =16V, V _{GS} =0V			1	μ A
Gate-Body Leakage	I _{GSS}	V _{GS} = ± 8V, V _{DS} =0V			± 100	nA
Gate Threshold Voltage	V _{GS(th)}	V _{DS} =V _{GS} I _D =250 μ A	0.5	0.8	1.5	V
Drain-Source On-State Resistance	R _{DS(ON)}	V _{GS} =4.5V, I _D =5A		18	24	m
		V _{GS} =2.5V, I _D =3A		24	32	
Forward Transconductance	g _{FS}	V _{DS} =5V, I _D =5A		15		S
Input Capacitance	C _{ISS}	V _{DS} =8V		1288		pF
Output Capacitance	C _{OSS}	V _{GS} =0V		297		
Reverse Transfer Capacitance	C _{RSS}	f=1.0MHz		230		
Turn-On Delay Time	t _{D(ON)}	V _D =10V, I _D =1A, V _{GEN} =4.5V, R _{GEN} =10 Ω , R _L =10 Ω		42		ns
Rise Time	t _r			10		
Turn-Off Delay Time	t _{D(OFF)}			86.5		
Fall Time	t _f			34		
Total Gate Charge	Q _g	V _{DS} =10V, I _D =5A, V _{GS} =4.5V		20		nC
Gate-Source Charge	Q _{gs}			2.7		
Gate-Drain Charge	Q _{gd}			5		
Diode Forward Voltage	V _{SD}	V _{GS} =0V, I _D =2A		0.8	1.2	V

Notes :

- a. Surface Mounted on FR4 Board, t ≤ 10 sec.
- b. Pulse Test : Pulse Width ≤ 300 μ s, Duty Cycle ≤ 2%.
- c. Guaranteed by design, not subject to production testing.

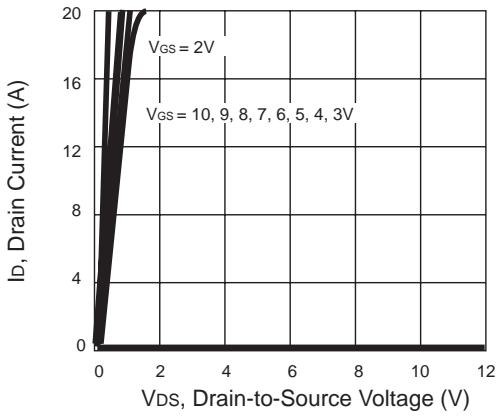

Figure 1. Output Characteristics

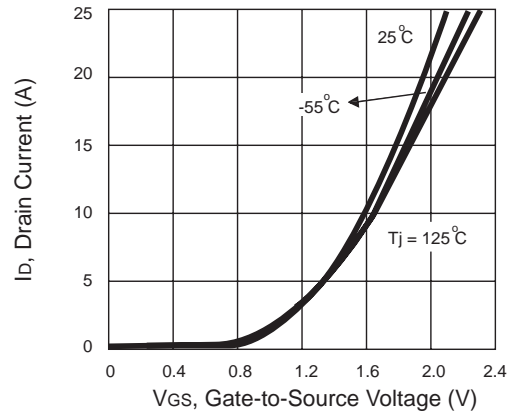

Figure 2. Transfer Characteristics

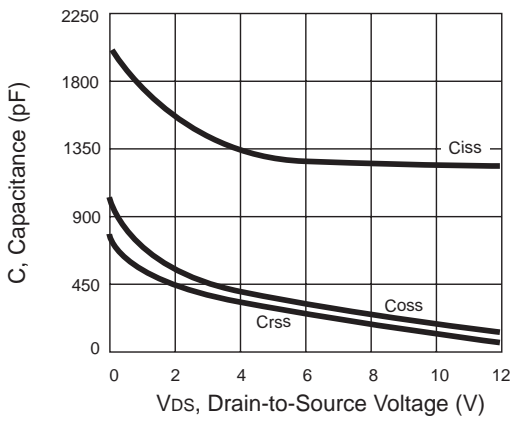

Figure 3. Capacitance

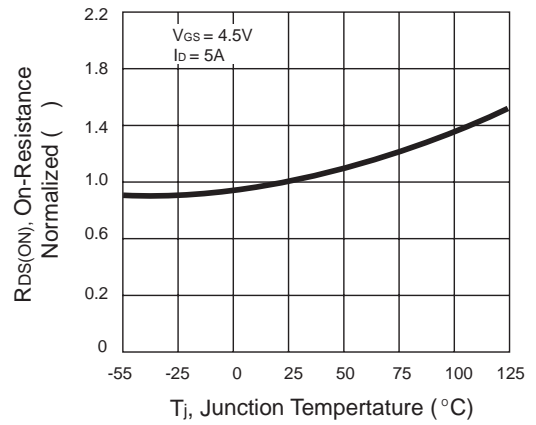

Figure 4. On-Resistance Variation with Temperature

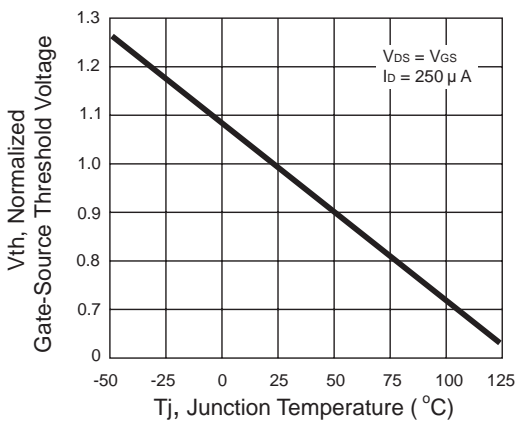

Figure 5. Gate Threshold Variation with Temperature

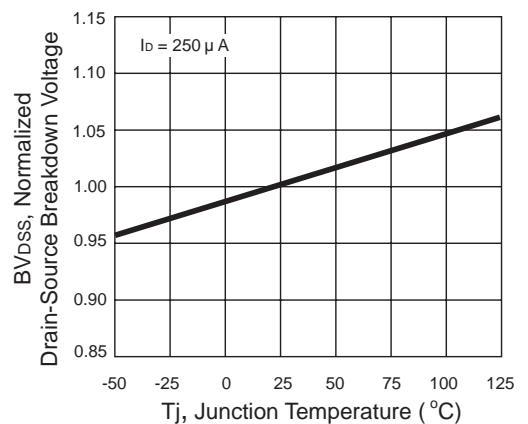

Figure 6. Breakdown Voltage Variation with Temperature

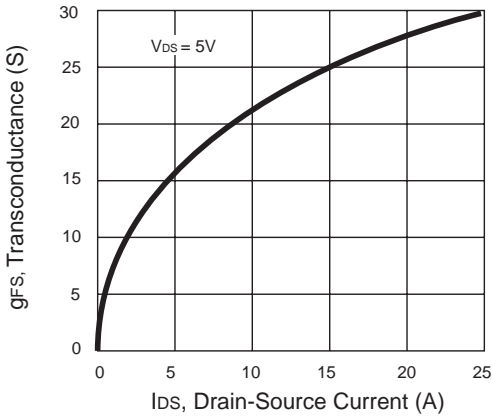

Figure 7. Transconductance Variation with Drain Current

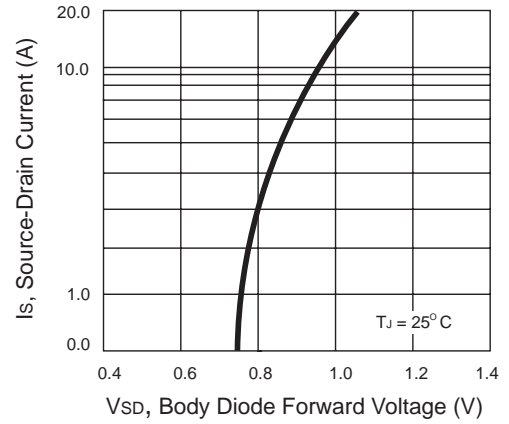

Figure 8. Body Diode Forward Voltage Variation with Source Current

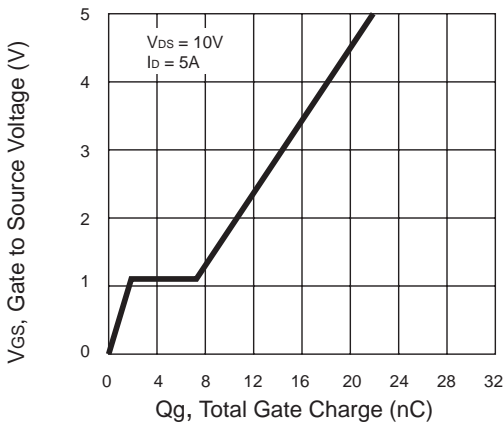

Figure 9. Gate Charge

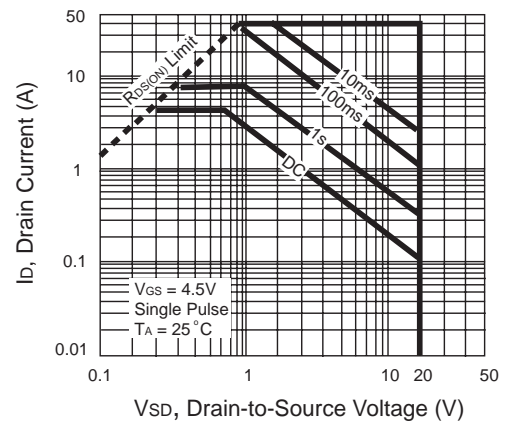

Figure 10. Maximum Safe Operating Area

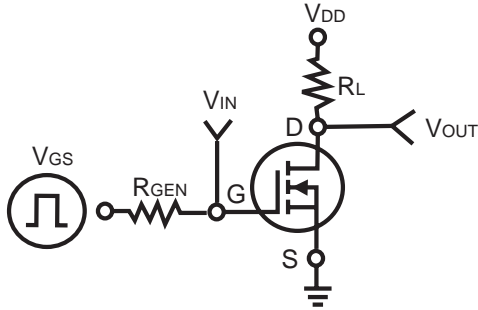

Figure 11. Switching Test Circuit

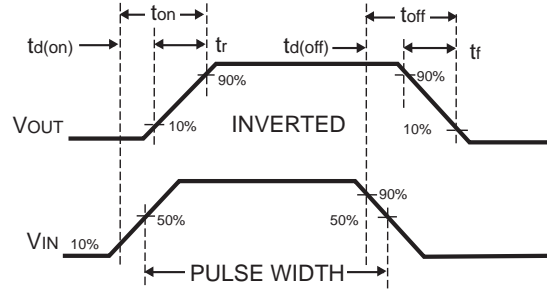

Figure 12. Switching Waveforms

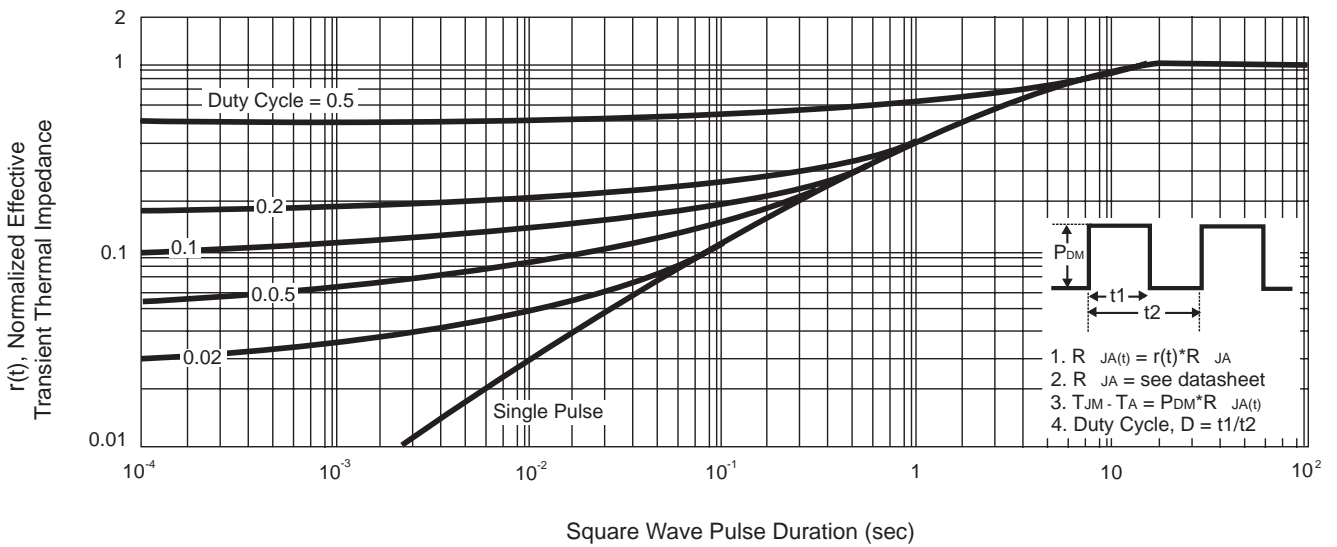
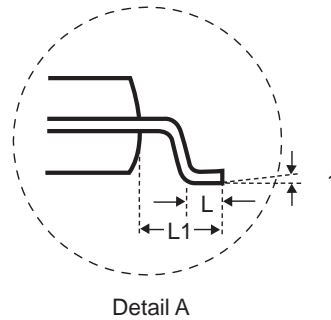
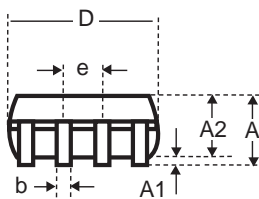
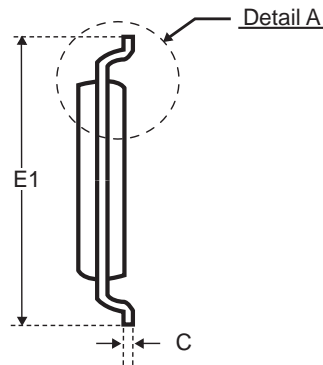
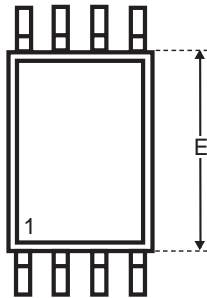

Figure 13. Normalized Thermal Transient Impedance Curve



Package Outline Dimensions

TSSOP-8



SYMBOLS	MILLIMETERS		INCHES	
	Min.	Max.	Min.	Max.
A	1.05	1.20	0.041	0.047
A1	0.05	0.15	0.002	0.006
A2	-	1.05	-	0.041
b	0.20	0.28	0.008	0.011
c	0.127		0.005	
D	2.90	3.20	0.114	0.126
E	4.30	4.50	0.169	0.177
E1	6.20	6.60	0.244	0.260
e	0.65 BSC		0.025 BSC	
L	0.50	0.70	0.020	0.028
L1	1.00		0.039	
	0°	8°	0°	8°



Carrier Tape & Reel Dimensions

TSSOP-8

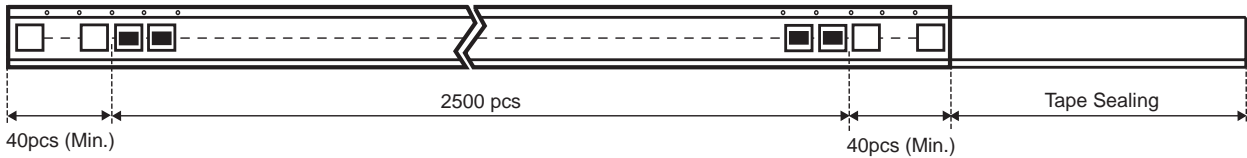
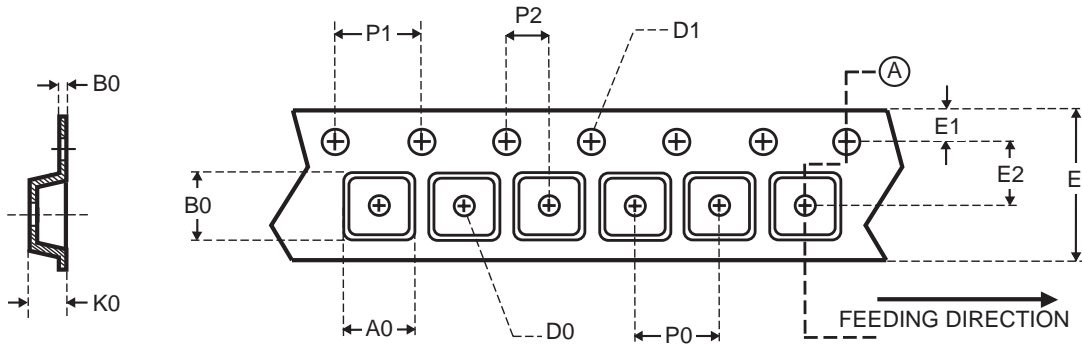

	A0	B0	K0	D0	D1	E	E1	E2	P0	P1	P2	
TSSOP-8	6.08	4.40	1.60	1.50 +0.10 -0.00	1.50 +0.10 -0.00	12.00 ±0.30	1.75	5.50 ± 0.05	8.00	4.00	2.00 ± 0.05	0.30 ± 0.05

UNIT : mm

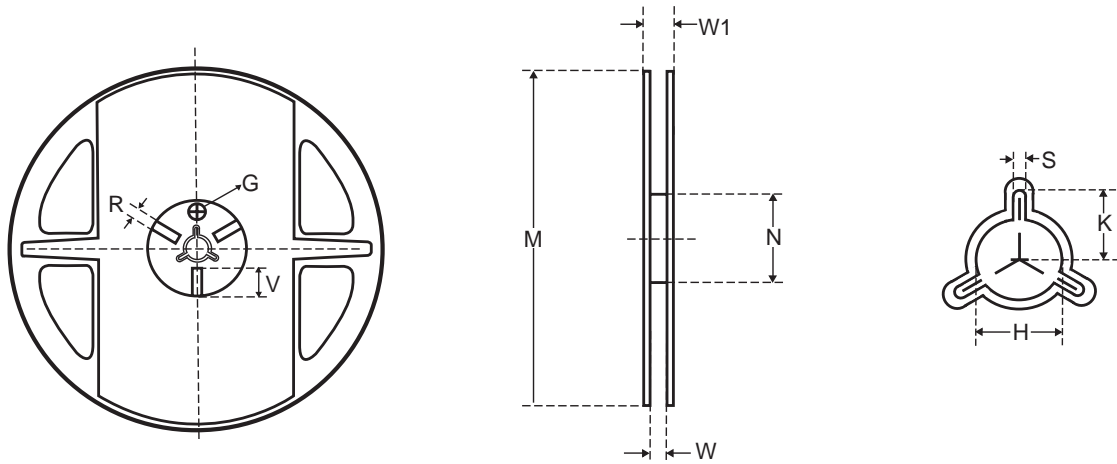

Tape size	Reel Size	M	N	W	W1	H	K	S	G	R	V
12mm	330	330	100	12.5	16.0	13.0 ±0.5	10.6	2.0 ±0.5	-	-	-

UNIT : mm